

PIN TYPE FORK

Pin type forks are hanged to the truck carriage using a welded tube/pin. The tube/pin dimensional tolerances and position are unique for each model and type of equipment.

Below we have 3 easy steps to help you define the Pin/Tube dimensions and position of your forks:

1. **Tube/Pin diameter:** measure the inside and outer diameter of the tube/pin.

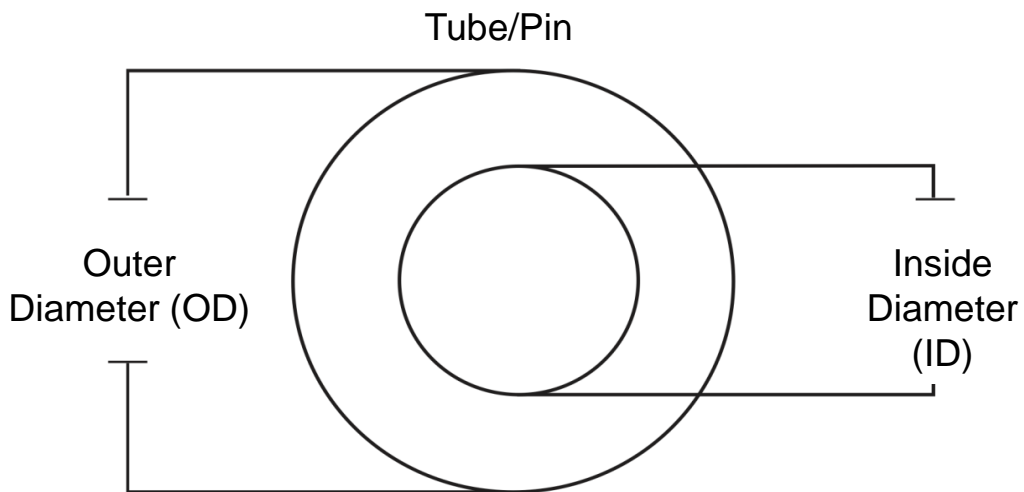

2. **Fork height:** measure the distance from the center of the tube/pin to the ground. This is known as the working height of the fork.

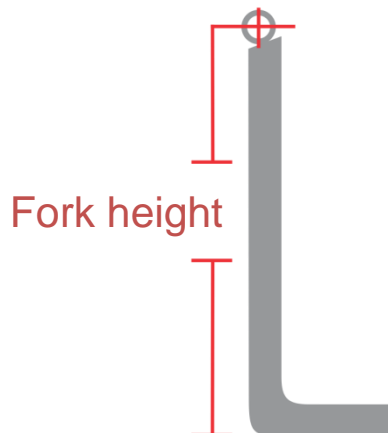

PIN TYPE FORK

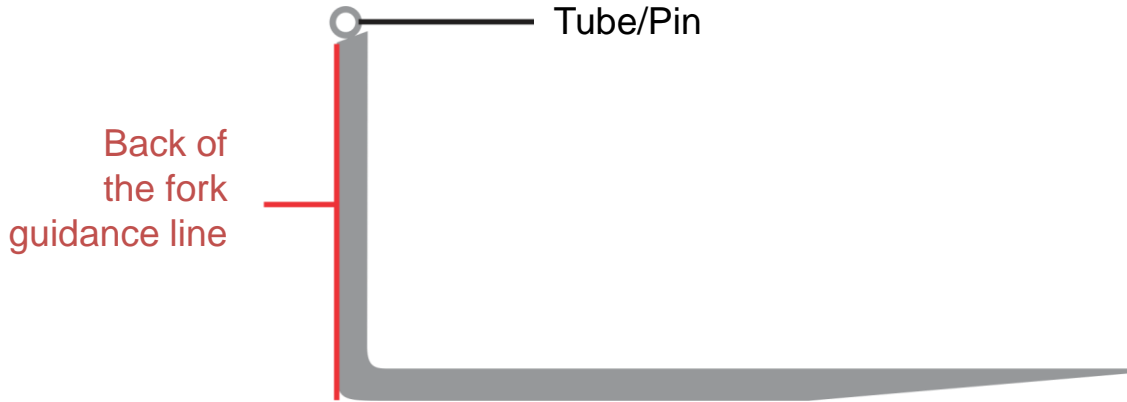

3. Tube/Pin position: there are 3 different tube/pin positions, Inline, Inset and Offset. You have to select one.

INLINE: the center of the Tube/Pin is positioned Inline in relation to the back of the fork (red guidance line).



Inline: no measure required

INSET: the center of the Tube/Pin is positioned Inset in relation to the back of the fork (red guidance line). In this case, you need to inform the Inset distance from the back.



Inset: measure distance from red line (back of the fork) to green line (center tube)

OFFSET: the center of the Tube/Pin is positioned Offset in relation to the back of the fork (red guidance line). In this case, you need to inform the Offset distance from the back.

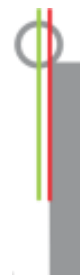

Offset: measure distance from red line (back of the fork) to green line (center tube)

